



Lifting Equipment Engineers Association

Guide to Documentation and Marking – Part 1 Manual Lifting Machines

Document reference LEEA 059-1 version 2 dated 23.02.15

Introduction.

This guide is aimed at manufacturers, distributors and users of lifting equipment within the European Economic Area. It has been developed as a quick reference guide to ensure that lifting equipment is supplied with the correct documentation and marking as required by current legislation, standards and best practice guidance.

LEEA 059-1 is one of a series of guides related to documentation and marking of a range of generic forms of lifting equipment as listed below:

- Part 1 – Manual Lifting Machines
- Part 2 – Powered Lifting Machines
- Part 3 – Lifting Machine Supporting Structures
- Part 4 – Lifting Accessories, Non-fixed load lifting attachments.
- Part 5 – Lifting Accessories, Slings
- Part 6 – General accessories and Components for slings.

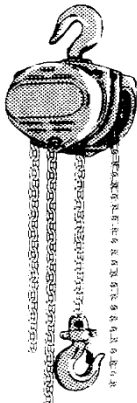
Item & Standard	Required Information
<p>Hand Operated Chain Hoist</p> <p>A hand operated lifting machine capable of raising, lowering or suspending a load.</p>  <p>BS EN 13157:2004 - Cranes-Safety-Hand Powered Lifting Equipment</p> <p>LEEA COPSULE – Section 3</p>	<p>Documents to be supplied in accordance with the relevant legislation & relevant standard:</p> <ul style="list-style-type: none"> - EC Declaration of Conformity (Guidance LEEA 030.1e) - Manufacturer’s instructions for use. (Guidance LEEA SI.12.3) <p>Marking requirements:</p> <ul style="list-style-type: none"> - CE Mark - Business name and address of the manufacturer - Identification mark; if any - Safe working load - The series or type designation. - Size and grade of the load chain - Year of manufacture. <p><i>Note if manufacturer does not provide a unique identification mark, then the owner of the equipment will be responsible for ensuring that the equipment is marked with one.</i></p> <p>Information Which Should Be Exchanged Between The User & Designer Or Supplier</p> <p>As blocks are frequently used for miscellaneous lifting purposes, precise details of the load to be lifted are not always available. In these circumstances, only a general specification can be given and this should include the following information:</p> <ol style="list-style-type: none"> 1. The safe working load or maximum load to be lifted. 2. The maximum extended dimension. 3. The maximum acceptable drawn up dimension (if headroom is important)

4. The range of lift.
5. The distance from the suspension level to the operating level. (This caters for the situation where the hand chain required is shorter than the load chain.)
6. Whether the block is to be used at an angle to the vertical.
7. The conditions of service and in particular any conditions which the user suspects might be hazardous, eg extremes of temperature, high probability of shock loading, uncertainty of weight of load.
8. The type of suspension, ie hook suspended or trolley mounted. In the case of trolley mounted blocks, the information required for the trolley is given in section 8 - Travelling trolleys.

With larger capacity blocks, the manufacturer may design the gear ratios such that more than one person is required to provide the operating effort. Where the availability of the manpower is likely to be a restriction, the purchaser should also specify the maximum acceptable effort.

Hand-operated Chain Lever Hoist

A lever operated lifting machine capable of raising, lowering or suspending a load

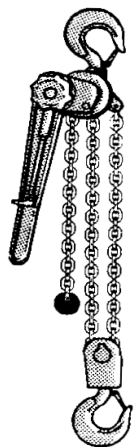

Documents to be supplied in accordance with the relevant legislation & relevant standard:

- **EC Declaration of Conformity (Guidance LEEA 030.1e)**
- **Manufacturer's instructions for use. (Guidance LEEA SI.12.3)**

Marking requirements:

- **CE Mark**
- **Business name and address of the manufacturer**
- **Identification mark, if any**
- **Safe working load**
- **The series or type designation.**
- **Size and grade of the load chain**
- **The direction of movement.**
- **Year of manufacture.**

Note if manufacturer does not provide a unique identification mark, then the owner of the equipment will be responsible for ensuring that the equipment is marked with one.

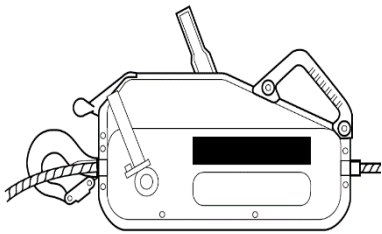
<p>BS EN 13157:2004 - Cranes-Safety-Hand Powered Lifting Equipment</p> <p>LEEA COPSULE – Section 4</p>	<p>Information Which Should Be Exchanged Between The User & Designer Or Supplier</p> <p>As chain lever hoists are frequently used for miscellaneous lifting purposes, precise details of the load to be lifted are not always available. In these circumstances, only a general specification can be given and this should include the following information:</p> <ol style="list-style-type: none"> 1. Intended application eg lifting, tensioning or pulling. 2. The safe working load. 3. The maximum extended dimension. 4. The maximum acceptable drawn up dimension if headroom is important. 5. The range of lift. 6. The type of chain required. 7. The conditions of service and in particular any conditions which the user suspects might be hazardous, eg extremes of temperature, high probability of shock loading, uncertainty of weight of load.
<p>Wire rope grip / pull lifting machine (Jaw winch).</p> <p>An appliance capable of carrying out either lifting operations or pulling operations. Must only be used with a rope designed to be fitted to a specific lifting / pulling machine.</p> 	<p>Documents to be supplied in accordance with the relevant legislation & relevant standard:</p> <ul style="list-style-type: none"> - EC Declaration of Conformity (Guidance LEEA 030.1e) - Manufacturer’s instructions for use. (Guidance LEEA SI.13.2) <p>Marking requirements:</p> <ul style="list-style-type: none"> - CE Mark. - Business name and address of the manufacturer. - Identification Mark, if any. - Application for which the machine is intended, i.e. lifting, pulling, man carrying. - Safe working load (or loads if intended for more than one application). - The series or type designation. - The size and grade of the ropes. - The marking of the direction of movement. - Year of manufacture. <p><i>Note 1: if manufacturer does not provide a unique identification mark, then the owner of the equipment will be responsible for ensuring that the equipment is marked with one.</i></p>

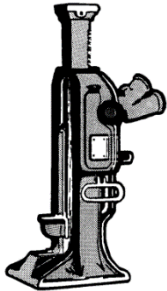
<p>BS EN 13157:2004 - Cranes- Safety-Hand Powered Lifting Equipment</p> <p>LEEA COPSULE – Section 5</p>	<p><i>Note 2: wire ropes used with lifting and pulling machines are detachable, and providing the correct specification, i.e. diameter and construction, are interchangeable. The following information should therefore be marked on the ferrule or terminal fitting of the wire rope:</i></p> <ul style="list-style-type: none"> - ID mark. - Safe working load. - Rope length. <p>Information Which Should Be Exchanged Between The User & Designer Or Supplier</p> <p>The following is the minimum information which should be exchanged between the user and the designer or supplier of a lifting and pulling machine:</p> <ol style="list-style-type: none"> 1. Intended application, eg lifting, tensioning, pulling or man-carrying. 2. Total maximum weight of the load to be lifted together with any other forces which may be superimposed on the load. 3. Frequency of use. 4. Environmental considerations such as heat or corrosive atmospheres. 5. Length of rope required. 6. In the case of hydraulically operated machines, the available power supply
<p>Jacks:- Mechanical</p> <p>Designed and used for raising and lowering a load over a limited range. Mechanically operated.</p> 	<p>Documents to be supplied in accordance with the relevant legislation & relevant standard:</p> <ul style="list-style-type: none"> - EC Declaration of Conformity (guidance LEEA 030.1e) - Manufacturer’s instructions for use. (guidance LEEA SI.21.2) <p>Marking requirements.</p> <ul style="list-style-type: none"> - CE Mark - Business name and address of the manufacturer - Design of series or type - Product code and designation of the machinery - Serial number or batch code

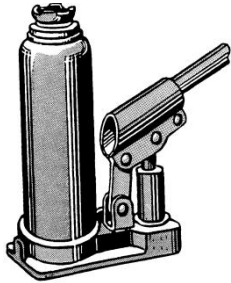

Hydraulic

Designed and used for raising and lowering a load over a limited range. Mechanically operated.

BS EN 1494:2000+A1:2008

LEEA COPSULE - Section 13

Note if manufacturer only provides a batch code, then the owner of the equipment will be responsible for ensuring that the equipment is marked with a unique identification.

- **Year of construction**
- **Rated load or loads if dependent on configuration.**
- **All necessary hydraulic, pneumatic or electrical information if an external hydraulic, pneumatic or electrical power supply is used.**
- **Hint on residual risks**

Information Which Should Be Exchanged Between the User & the Designer or Supplier

Jacks are readily available in a wide range of designs, sizes & capacities, some including special features making them suitable for certain applications. The exchange of information should therefore be as detailed as possible. As by their nature jacks are often moved from site to site & used to handle a wide variety of loads, precise details are not always available & in these cases only a general specification can be given. In many cases, the requirements will be basic & the information easily exchanged. In all other cases the following minimum information should be exchanged:

1. Capacity. Where possible, full details of the load to be lifted, including dimensions, weight & details of jacking points.
2. Type of jack, ie hydraulic, ratchet, screw or journal.
3. Details of working dimensions eg closed height, extended height, size of head of jack, height & size of toe etc.
4. Details of the intended use, including utilization & required accuracy of load placement. Where the jack is required for general purpose use, it may be necessary to impose limits on the use. The manufacturer's instructions should therefore be sought & their recommendations followed.
5. Environmental conditions, eg outdoor or indoor use, use in corrosive atmospheres, use in hazardous areas, use with dangerous loads etc.
6. Details of finish, including any special paint or protective finish.
7. Any special features or optional fittings such as claw attachment, gauges etc.
8. Any other technical requirements.
9. Operational & maintenance instructions, including limitations of use.

Manual Travelling Girder Trolleys

Provide a means of moving a load suspended on a rolled steel structure in conjunction with either a hand or power operated lifting machine.

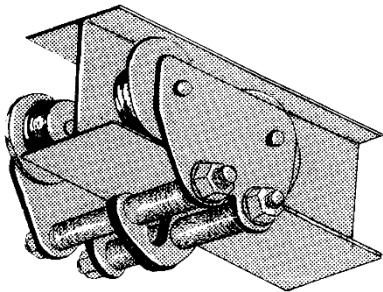

**BS EN 13157- Cranes-Safety-
Hand Powered Lifting
Equipment**

LEEA COPSULE – Section 8

Documents to be supplied in accordance with the relevant legislation & relevant standard:

- **EC Declaration of Conformity (Guidance LEEA 030.1e)**
- **Manufacturer's instructions for use. (Guidance LEEA SI.16.3)**

Marking requirements

- **CE Mark**
- **Business name and address of the manufacturer**
- **Series or type designation**
- **Identification number, if any**

Note if manufacturer does not provide a unique identification mark, then the owner of the equipment will be responsible for ensuring that the equipment is marked with one.

- **Safe working load.**
- **Year of manufacture**
- **Indication as to whether it is suitable for hand or power operated lifting appliances.**
- **The range of beam sizes it is designed to fit.**

Information Which Should Be Exchanged Between The User & Designer Or Supplier

Although not required by legislation, new girder trolleys will usually be issued with a manufacturer's record of proof load testing in addition to, although possibly combined with, the EC DoC. This document forms an important part of the record of the trolley. It should be retained & cross referenced to the trolley's historical records for inspection by the Competent Person or HSE.

As girder trolleys are frequently used for miscellaneous lifting applications, precise details of the load to be carried are not always available. In these circumstances, only a general specification can be given and this should include the following:

1. Type of trolley required.
2. Details of the runway beam section to which the trolley is to be fitted. These details must be sufficient

to fully identify the particular rolled steel section or in the case of a fabricated section, the various elements from which it is manufactured. In addition, details of fixing bolts, clips, splices etc are required to ensure that they will not foul the load bar, trolley wheels or anti-tilt device where fitted. (See figure 1)

3. Details of the supporting structure of the runway including clearance dimensions to other structures or items of plant to ensure that there will be no external obstruction to the operation of the trolley and lifting appliance.
4. The total maximum weight to be lifted.
5. The type (including whether manual or power operated) and class of use of lifting appliance to be used with the trolley.
6. Details of the load bar or suspension point of the trolley and the attachment point of the lifting appliance(s) to be fitted.
7. If a geared trolley is specified, then the suspension and operating levels are required so that the length of hand chain may be determined.
8. The minimum radius curve, if any, of the runway.
9. Environmental considerations such as extremes of temperature or corrosive atmospheres.
10. Indicate whether: universal beam (UB), rolled steel joist (RSJ), rolled steel channel (RSC), etc. Also indicate end stops, joint plates etc.

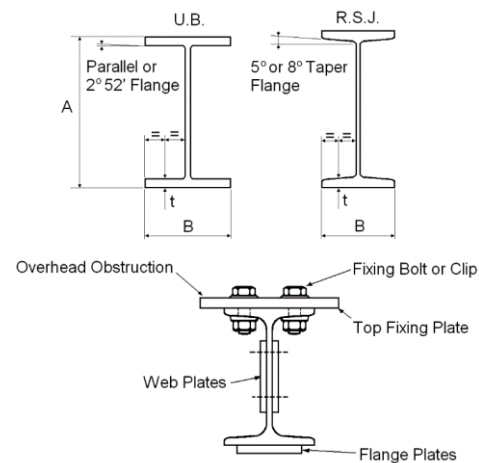

Figure 1 Types of beam

	<p><i>Note: As an example, a trolley may be described as follows: 250kg working load limit: Gear operated: Four plain bearing wheels: Rigid trolley: Flange width 6" UB: Suitable for use with hook suspended hand chain block.</i></p>
--	---

APPENDIX 1

The following appendix has been developed as a guide to support the requirements of LEEA 059.

The relevant legislation is:

- Machinery Directive 2006/42/EC
- Supply of Machinery (Safety) Regulations 2008
- Provision and Use of Work Equipment Regulations 1998
- Lifting Operations and Lifting Equipment Regulations 1998
- Management of Health and Safety at Work Regulations 1999.

It is emphasised that this guidance applies to legal requirements only. If the equipment or service provided is to a standard or other specification, additional documents or marking may be required. For each product type within the guidance these marking requirements have been specified

Lifting equipment includes any manual or power operated lifting machine and any lifting accessory which can connect the load to the lifting machine or the lifting machine to its supporting structure.

The guiding principle for all documentation is that it must be legible, complete and accurate. Information which is untrue can result in prosecution. In particular the traditional practice of 'back to back' documentation is now unacceptable.

NEW EQUIPMENT

New lifting equipment must comply with The Supply of Machinery (Safety) Regulations 2008 as amended in 2011. (SOMSR) The Responsible Person must issue an EC Declaration of Conformity (DOC) and affix the CE marking. This document and marking are evidence that the Responsible Person has claimed compliance. The equipment must also be accompanied by instructions. The information to be contained in the EC Declaration of Conformity and the instructions and the other marking requirements are defined within the guidance for each product type.

Note: Some machinery and safety components are subject to special attestation procedures. These are listed in Annex IV of the Machinery Directive (Annex D of the Supply of Machinery (Safety) Regulations) In general, such special procedures only apply to lifting equipment if it is to be used for lifting persons.

An employer has a duty under Regulation 10 of PUWER98 to ensure that any new equipment has been designed and constructed in compliance with the essential requirements contained in SOMSR. The EC Declaration of Conformity and the CE marking are evidence that it complies.

An employer has a duty under Regulation 9 of LOLER to have lifting equipment thoroughly examined (which includes any appropriate supplementary testing) before first use. There is an exemption for new equipment if it has not been used and the employer has received an EC Declaration of Conformity made not more than 12 months before the equipment has been put into use. However if safety depends on the installation conditions, a thorough examination is required to ensure that it has been installed correctly and is safe to operate. Following any thorough examination, the person making the examination has a duty under Regulation 10 of LOLER to make a report of the examination. The information to be contained in that report is listed in LOLER Schedule 1 and LEEA have produced example templates, refer to LEEA 030.1a

The simplest solution

In most cases, the simplest way to comply with the legal requirements is for the manufacturer to issue the EC Declaration of Conformity, affix the CE marking and provide instructions. If the equipment is not supplied direct to the end user, those in the supply chain should pass on the original documents and not alter any markings. The end user should obtain and keep the original documents. If the exemption applies, the equipment can be put into use. If, at the point of being put into use, the exemption does not apply or if safety depends on the installation conditions, the employer should have it thoroughly examined by a competent person and obtain and keep the report of that examination. Provided the report states that it is safe to operate, the equipment can be put into use.

Problems and alternative solutions

(1) Your supplier has not provided the DOC

The equipment should be rejected until it is provided.

(2) The DOC covers a bulk supply which you will sell in smaller quantities

Provide a copy to your customer. However it is likely that the exemption under LOLER will not apply so thoroughly examine the equipment and issue a LOLER report. Alternatively combine the two with a statement on the LOLER report to the effect that the Responsible Person issued a DOC for the item. Keep the DOC and let your customer see it if requested.

(3) Your supplier will sell direct to your customer so you do not wish to reveal your source

The marking requirements of SOMSR for lifting machines include the name and address of the manufacturer. For lifting accessories it includes identification of the manufacturer. You cannot therefore legally hide this information. If your supplier is not the manufacturer but has passed on the original documents, the simplest solution applies. If your supplier is the manufacturer then either use the alternative in (2) above or 'own brand' it as in (4) below.

(4) Equipment made by others but sold in your name

This is known as 'own branding'. **The Commission guidance is that if you appear to be the manufacturer you must accept all the obligations of a manufacturer including assembly of the technical file, declaration of conformity, marking and compliance with the essential safety requirements.** If you are not in possession of the technical file you should have a written mandate from the manufacturer that authorises you as their legal representative and details explicitly which obligations set out in article 5 are entrusted to you. As a minimum you must be made responsible for compiling the technical file and making it available to the authorities if requested during market surveillance.

Note: The technical file needn't be paper based, electronic records are acceptable and only a Member State can expect to have sight of it following a substantiated request.

(5) Equipment assembled from several items or modified

The person assembling equipment is regarded as the manufacturer of the assembly. If items within the assembly have a DOC, that forms part of the technical file for the assembly. Similarly anyone modifying equipment and/or changing its intended use is regarded as the real manufacturer. In both cases the obligations include assembly of the technical file, issuing of the DOC, marking and compliance with the essential requirements including provision of instructions.

(6) Equipment made by others which you are asked to test and certify

Be cautious about what you are being asked to do. Traditionally a certificate of test and examination was all that was required to take the equipment into service. Now it is only one ingredient of the technical file. If you are testing it on behalf of the manufacturer as part of his verification process, then he should provide a test specification for you to work to after which you should simply report the results. However

some internet sources do not provide any documentation and customers will send such equipment or home made equipment expecting you to test it and certify it as safe to use. In general, equipment which should be CE marked and have a DOC but hasn't, should be referred back to the manufacturer. If you go beyond simply testing, examining and reporting the results, you may be taking a risk.

If it is a test and examination of a new installation and safety depends upon the installation conditions, then Regulation 9 of LOLER applies. Check also that your customer has the DOC(s) from the manufacturer(s) and that the equipment has been installed in accordance with their instructions. If it is an assembly of items or includes a modified item, check who is responsible for the assembly or modification. See (5) above.

(7) Equipment supplied without instructions

There is a requirement under SOMSR that the equipment is accompanied by instructions for use. Therefore, as a general rule, the equipment should be rejected until such instructions are supplied. If it is general purpose equipment, without any characteristics particular to the design, then generic instructions are an acceptable alternative, eg the LEEA safety information leaflets.

(8) Equipment supplied without CE marking

In general, all complete items of lifting equipment should have the CE marking. Sub assemblies and components are not usually marked. Some items, such as shackles, may be made for non-lifting applications. If the item is supplied complete, intended for lifting applications and not marked, reject it.

(9) Equipment with a Declaration of Incorporation

An EC Declaration of Incorporation (DOI) is a device to legally market machinery which can function but is not complete and may not be safe. It is a statement that the machinery is not to be used until incorporated into an assembly for which a DOC is issued. If you buy and incorporate such machinery, you have the obligations of the manufacturer of the finished assembly.

IN-SERVICE EQUIPMENT

An employer has a duty under Regulation 9 of LOLER to have his lifting equipment thoroughly examined at specified maximum periods or in accordance with an examination scheme and after any exceptional circumstances which are liable to jeopardise the safety of the equipment. Following any thorough examination, the person making the examination has a duty under Regulation 10 of LOLER to make a report of the examination irrespective of whether or not the equipment is found safe to use.

The report must be made to the employer and any person from whom the equipment has been hired or leased. If the person making the examination is of the opinion that there is a defect involving an immediate or imminent risk of serious personal injury, he has a duty to send a copy of his report to the relevant enforcing authority. (Generally the HSE) The information to be contained in that report is listed in LOLER Schedule 1 and LEEA have produced example templates, refer to LEEA 030.1a.